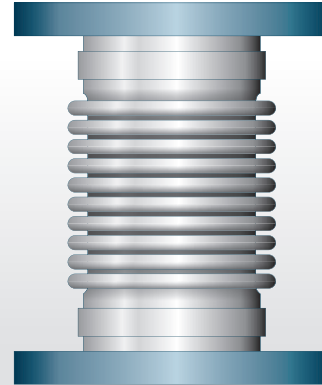

DESIGN CONDITIONS

Max. Design Pressure	25 Bar
Max. Design Temperature	300°C
Test Pressure	38 Bar
Bellow Options	321/316/Alloy
Flange Options	Carbon Steel/Stainless Steel
Drilling Options	PN 25

NOTE: If not specified our engineers will automatically select the first option. *i.e.* 321, carbon steel, etc.

**GENERAL INFORMATION**

The standard SAF range is comprised of stainless steel expansion joints having carbon steel flanges. These expansion joints are designed to absorb axial movement which results mainly from thermal expansion and contraction of pipework. Recommendations contained in our literature (see Application and Installation section) should be followed. These expansion joints will extend in length when under pressure conditions unless adequately restrained by anchors and guides. Preferably the joints should be located adjacent to anchors with the first guide not more than 4 pipe diameters from the expansion joint. The next guide should be positioned 14 pipe diameters to the first, and subsequent guides as necessary, to ensure the pipeline is free from sag or pressure deflection. These expansion joints are supplied at a neutral length but can be "cold drawn" on installation. Particular care should be taken to make sure the expansion joints are installed with the flow arrows in the right direction.

NOMINAL SIZE (mm)	PIPE DIAMETER (mm)	PART NUMBER	MOVEMENT		OVERALL LENGTH (mm)	EFFECTIVE AREA (cm ²)	AXIAL SPRING RATE (n/mm)
			+ or - mm	TOTAL mm			
50	60.3	SAF/0050/25/001	25	50	208	37	195
65	76.1	SAF/0065/25/001	25	50	208	56	250
80	88.9	SAF/0080/25/001	25	50	208	75	577
100	114.3	SAF/0100/25/001	25	50	208	118	747
125	139.7	SAF/0125/25/001	38	76	314	187	457
150	168.3	SAF/0150/25/001	38	76	314	261	551
200	219.3	SAF/0200/25/001	50	100	352	441	499
250	273	SAF/0250/25/001	50	100	352	665	1486
300	323.9	SAF/0300/25/001	50	100	352	918	1772
350	357	SAF/0350/25/001	45	90	325	1200	1566
400	406	SAF/0400/25/001	45	90	325	1530	3497
450	457	SAF/0450/25/001	45	90	325	1929	3053
500	508	SAF/0500/25/001	45	90	325	2342	3392
550	559	SAF/0550/25/001	45	90	310	2895	2593
600	610	SAF/0600/25/001	45	90	310	3394	2643

For more information please call our sales engineers on 01663 748 200

All Thermosel® products are made by Pearwalk Engineering Ltd.
Furness Vale Business Centre, Calico Lane, Station Road, High Peak, SK23 7SW England
Tel: 01663 748 200 | Fax: 01663 746 834 | www.pearwalkengineering.com

PLAN VIEW FOR A FLANGED SINGLE AXIAL EXPANSION JOINT

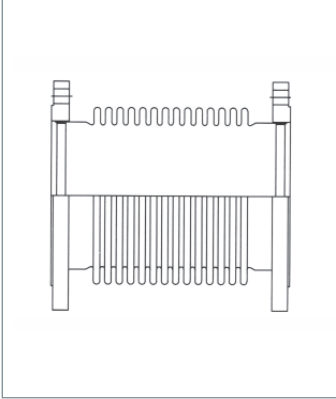

A TYPICAL APPLICATION EXAMPLE OF SINGLE AXIAL SYSTEM

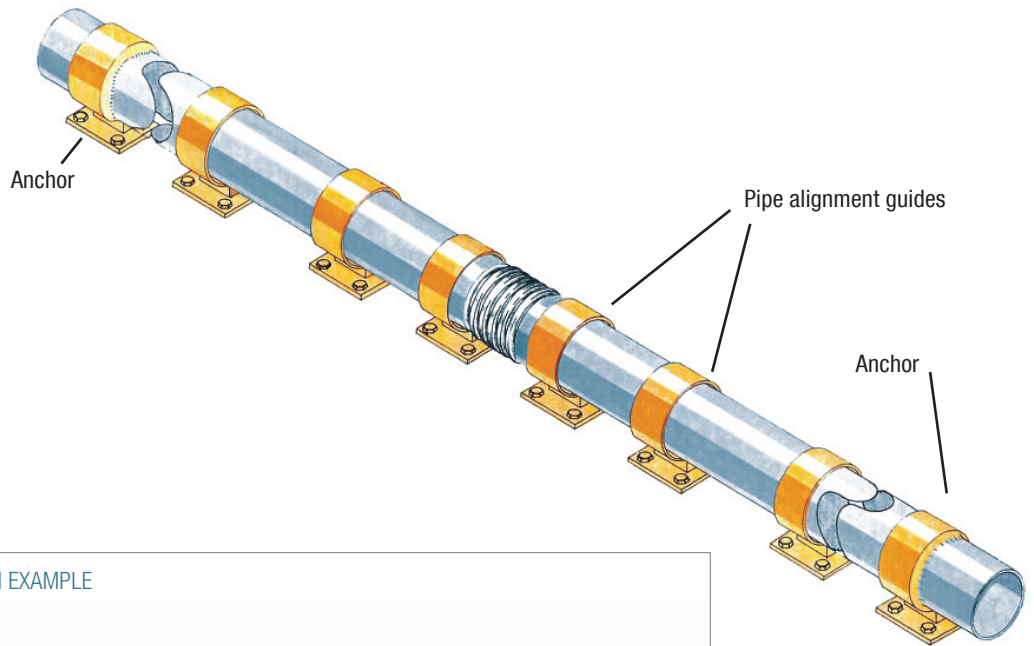

PLAN VIEW OF A TYPICAL APPLICATION EXAMPLE

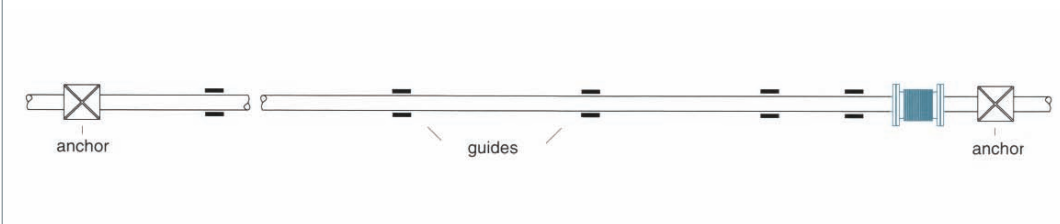

The correlation between working temperature and pressure can be found on our temperature correction chart (see last page).

APPLICATION INFORMATION

Figure A typifies good practice in the use of a single expansion joint to absorb axial pipeline expansion. Note the use of one expansion joint between two main anchors (MA), the nearness of the expansion joint to an anchor, the closeness of the first alignment guide (G1), the spacing between the first alignment guide and the second alignment guide (G2), and the spacing of the intermediate guides (G) along the balance of the line.

Figure B typifies good practice in the use of a double expansion joint to absorb axial pipeline expansion. Note the addition of the intermediate anchor (IA) which, in conjunction with the two main anchors, divides the pipeline into individual expanding sections, so that there is only one expansion joint between any two anchors. Note also the closeness of the first alignment guide (G1) to each expansion joint, the spacing between the first alignment guide and the second alignment guide (G2), and the spacing of the intermediate guides (G) along the balance of the each pipe section.

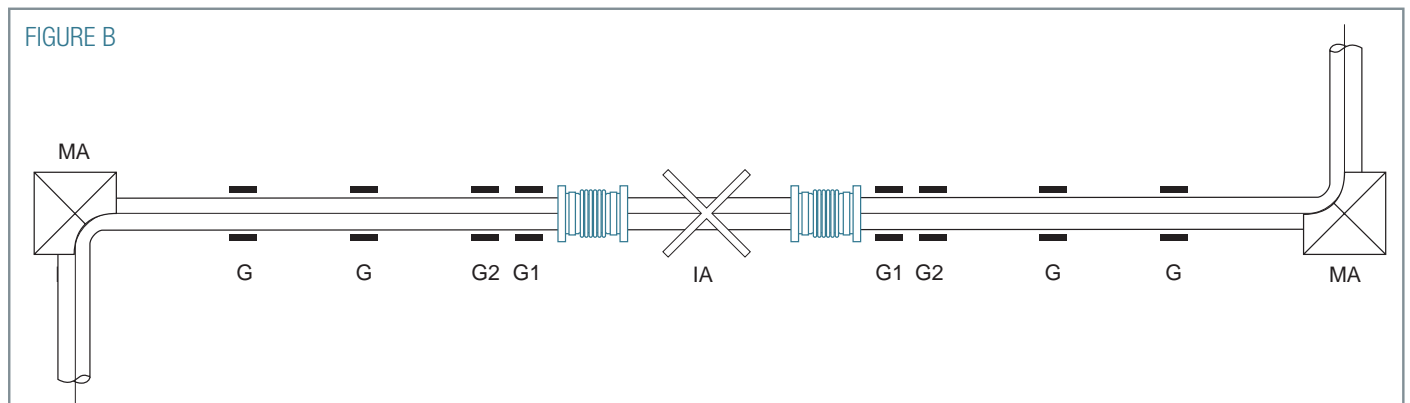
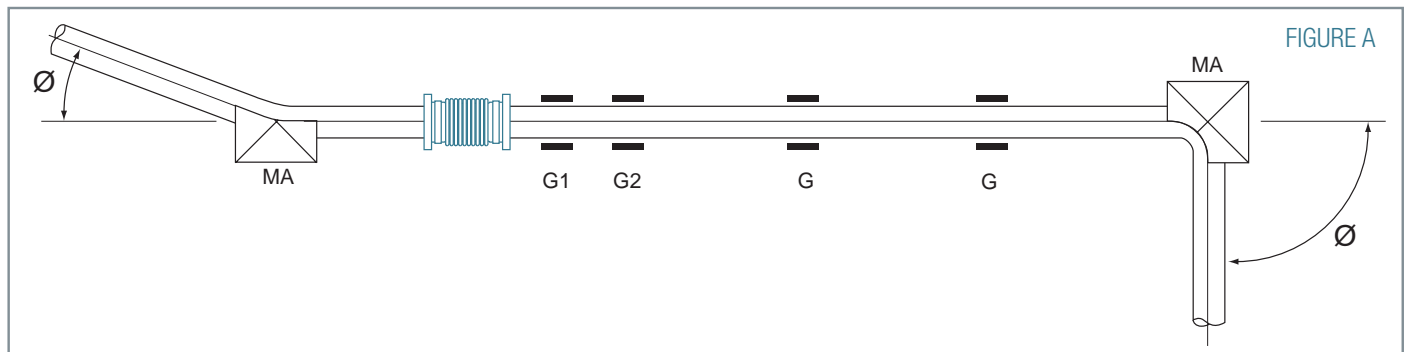

For more information please call our sales engineers on 01663 748 200

All Thermosel® products are made by Pearwalk Engineering Ltd.
 Furness Vale Business Centre, Calico Lane, Station Road, High Peak, SK23 7SW England
 Tel: 01663 748 200 | Fax: 01663 746 834 | www.pearwalkengineering.com



FIGURE C

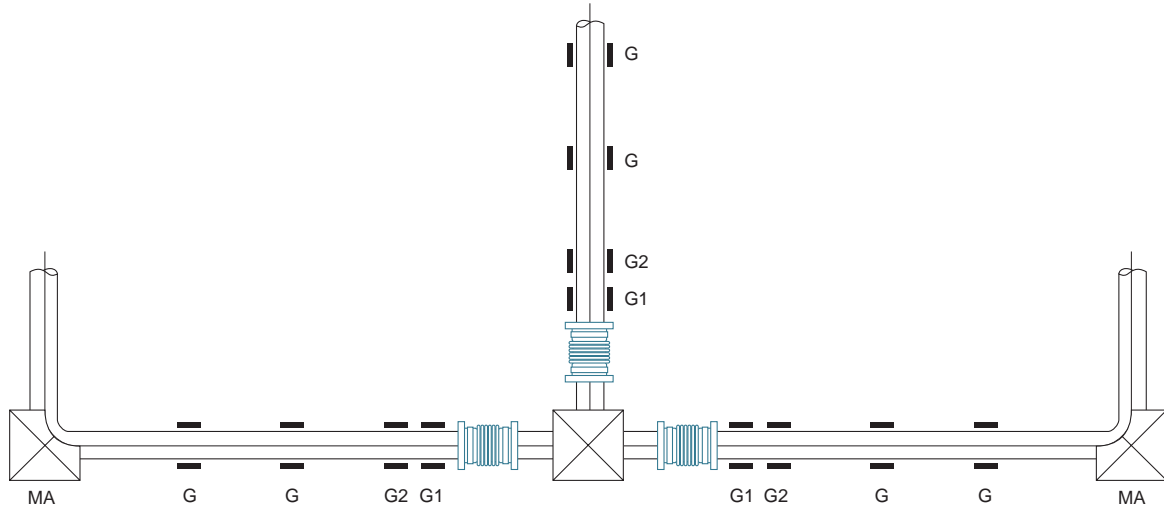

Figure C typifies good practice in the use of expansion joints to absorb axial pipeline expansion in a pipeline with a branch connection. The anchor at the junction, which in this case is a tee, is a main anchor (MA), designed to absorb the thrust from the expansion joint in the branch line. Note the nearness of each expansion joint to an anchor, the closeness of each first alignment guide (G1), the spacing between the first alignment guide and the second alignment guide (G2), and the spacing of the intermediate guides (G) along the balance of the each pipe section.

FIGURE D

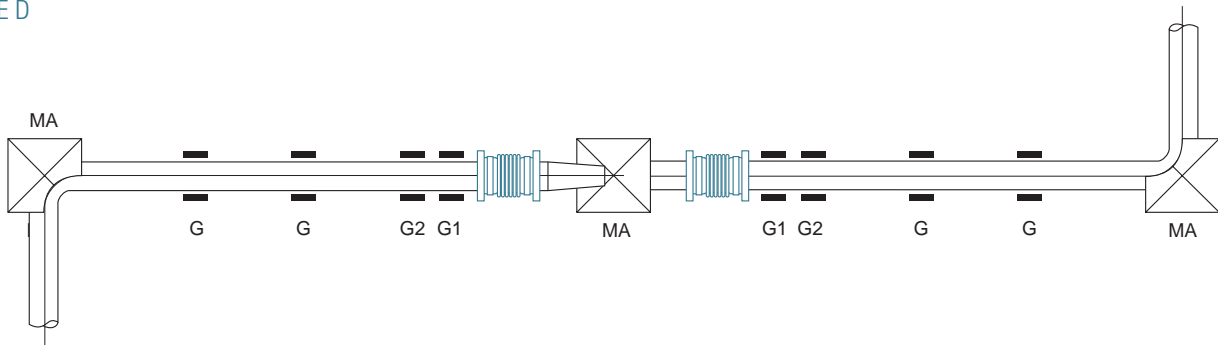

Figure D typifies good practice in the use of expansion joints to absorb axial pipeline expansion in a pipeline containing a reducer. The anchor at the reducer is the main anchor (MA), designed to absorb the difference in the thrusts of the expansion joints on each side of the reducer. Note the nearness of each expansion joint to an anchor, the closeness of each first alignment guide (G1), the spacing between the first alignment guide and the second alignment guide (G2), and the spacing of the intermediate guides (G) along the balance of the each pipe section.

FIGURE E

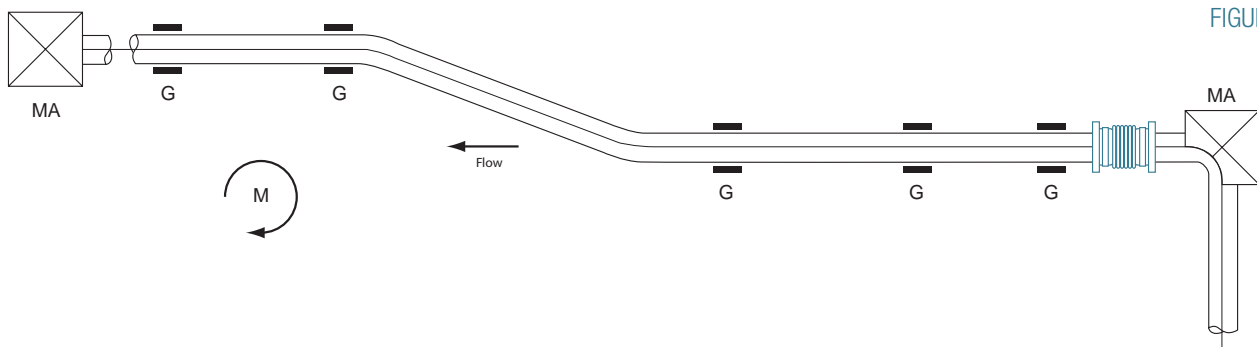

Figure E shows the application of a single expansion joint to a pipeline containing an offset. it should be noted that applications of this type are not usually recommended and will perform satisfactory only within certain limits. As in the first figure, the line is provided with main anchors at each end to absorb the pressure, movement loading, and guide friction. Where the line contains an offset, this load must first be transmitted through the offset leg, resulting in a moment on the piping. Where the line size is small, the offset appreciable, or where the pressure and movement forces are relatively high, this configuration may result in over stressing, or distortion of the piping and guides.

Note the nearness of each expansion joint to an anchor, the closeness of each first alignment guide (G1), the spacing between the first alignment guide and the second alignment guide (G2), and the spacing of the intermediate guides (G) along the balance of the line. Guides should be installed near both ends of the offset leg to minimise the effects of the bending moment on the system.

For more information please call our sales engineers on 01663 748 200

All Thermosel® products are made by Pearwalk Engineering Ltd.
 Furness Vale Business Centre, Calico Lane, Station Road, High Peak, SK23 7SW England
 Tel: 01663 748 200 | Fax: 01663 746 834 | www.pearwalkengineering.com



INSTALLATION REQUIREMENTS

Main anchors by definition are installed where directional changes take place, at the end of a line or between expansion joints of different size. They have to carry the full pressure thrust, the spring forces, and the frictional forces due to alignment guides and supports, and in some cases, the weight of piping, fittings and contents.

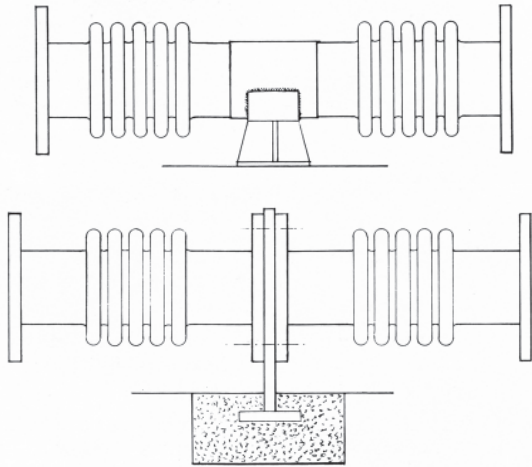

The design of such anchors is therefore, beyond the scope of the design engineer, unless full details of the entire structure are provided. In these cases, anchors may be furnished as an integral part of the expansion joint.

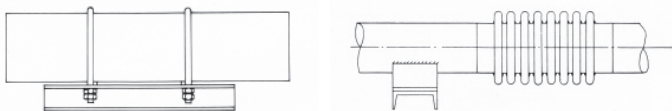

An intermediate anchor divides a pipe system into an individual expanding section, and is only responsible for the forces imposed upon it by this section, i.e. it includes only for the spring forces, friction of guides and possibly the wind load and weight etc., as it effects each section of pipe. Intermediate anchors may be built into expansion unit assemblies by arrangement with the manufacturer and may lead to economies by the elimination of flanges or other fittings. Directional anchors or guides are designed to absorb loading in one direction whilst permitting motion in another. It may constitute either a main or an intermediate anchor, depending upon the application. Clearly, such guides are required to have a minimum of friction in order to reduce the loading elsewhere, and ensure its proper functioning as a guide.

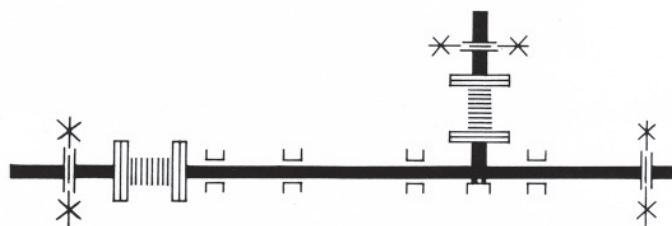
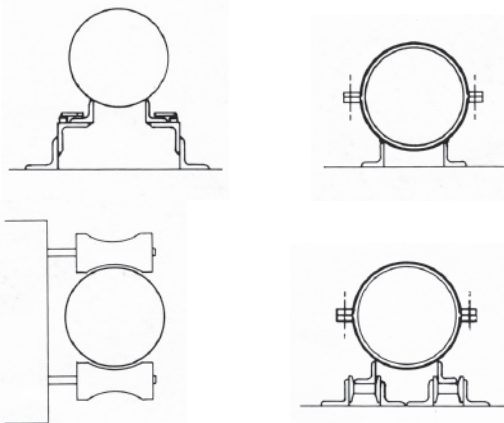

INSTALLATION INSTRUCTIONS

The position of anchors and guides relative to expansion joints will vary with each installation and type of joint. The following is a list of basic rules for expansion joints, in accordance with E.J.M.A. (Expansion Joint Manufacturers Association), and the new British Standard Code of Practice for metallic bellows expansion joints, which provide a useful guide and will ensure a satisfactory installation.

- 1 Divide the pipe length into sections ensuring that the expansion of each section is within the allowable movement of a bellows joint. Locate intermediate anchors at the end of each section and main anchors at each end of the pipe run.
- 2 Locate expansion joints adjacent to each other and position the guides so that the first is not more than 4 pipe diameters from the expansion joint and the second not more than 14 pipe diameters from the first guide.
- 3 Position other guides and supports according to the piping weight, diameter and internal pressure to ensure freedom from sag or pressure deflection, refer to Data Sheet 1 (004/79/1)
- 4 Check that each guide is approximately 1.5 pipe diameters in length for pipes up to 8" diameter and approximately 12" long for larger sizes. Some approved designs are illustrated.
- 5 Never use more than one expansion joint between two anchors, unless they form part of a expansion joint assembly, such as an articulated joint and have been supplied with full knowledge of the pipe layout.
- 6 Thermosel® expansion joints may be cold drawn from their neutral position by up to half the total rated expansion. Data Sheet 1 (004/79/1) provides for installation at different ambient temperatures.
- 7 Pipe anchors should be located at changes in pipe direction, or whenever necessary to divide straight lengths to suit maximum expansion joint movement. Joints should be at least 4 pipe diameters from dampers, gate valves, butterfly valves or other accessories.
- 8 Expansion joints should never be used to correct pipe alignment or fitting errors beyond the design parameters of the joint. Torsional strain for example is not permitted and flange holes must therefore be carefully aligned.
- 9 When internal sleeves are fitted, directional flow arrows indicate the correct way to install the unit with respect to the actual direction of flow.
- 10 Shipping restraints (painted red) when supplied, maintain the overall length of the assembly for shipment. These devices may also be used to pre-compress, pre-extend or laterally offset the bellows, to facilitate correct installation, and must be removed prior to test or commissioning.
- 11 The convolutions of stainless steel expansion joints must be protected from weld splatter. Foreign material entering the space between the convolutions, either internally or externally, will prevent correct operation of the joint and may result in premature failure.
- 12 Standard expansion joints are pressure tested prior to despatch to 1.5 times the operating pressure, and pipework should not be tested in excess of this. Testing should not be carried out until the anchors are secure and the pipework correctly guided.
- 13 Where a gaseous system is to be hydraulically tested, determine whether the piping and bellows joints require additional temporary support to carry the weight of water to be used during the test.
- 14 Main anchors must be designed to withstand the highest combined effects of pressure thrust, spring rate force and the friction force generated by guides. See Data Sheet 4 (007/79/1).
- 15 Insulation materials containing sulphides, chlorides or other contaminants must not be used on stainless steel expansion joints and must not be allowed to fall between the convolutions. Aluminium, lead or zinc bearing paints, must not be used on stainless steels.

For more information please call our sales engineers on 01663 748 200

All Thermosel® products are made by Pearwalk Engineering Ltd.
Furness Vale Business Centre, Calico Lane, Station Road, High Peak, SK23 7SW England
Tel: 01663 748 200 | Fax: 01663 746 834 | www.pearwalkengineering.com

THERMOSEL®

SAFETY RECOMMENDATIONS

Inspection prior to Start-up or Pressure Test

Expansion joints are usually considered to be non-repairable items and generally do not fall into the category for which maintenance procedures are required. However, immediately after the installation is complete a careful visual inspection should be made of the entire piping system to ensure that there is no evidence of damage, with particular emphasis on the following:

- 1 Are anchors, guides, and supports installed in accordance with the system drawings?
- 2 Is the proper expansion joint in the proper location?
- 3 Are the flow direction and pre-positioning of the expansion joint correct?
- 4 Have all of the expansion joint shipping devices been removed?
- 5 If the system has been designed for gas, and is to be tested with water, has provision been made for proper support of the additional dead weight load on the piping and expansion joint? Some water may remain in the bellows convolutions after the test. If this is detrimental to the bellows or system operation, means should be provided to remove this water.
- 6 Are all guides, pipe supports and the expansion joints free to permit pipe movement?
- 7 Has any expansion joint been damaged during handling and installation?
- 8 Is any expansion joint misaligned? This can be determined by measuring the joint overall length, inspection of the convolution geometry, and checking clearance at critical points on the expansion joint and at other points in the system.
- 9 Are the bellows and other movable portions of the expansion joint free of foreign objects?

Inspection during and immediately after pressure test

WARNING: Extreme care must be exercised while inspecting any pressurised system or component

A visual inspection of the system should include the following:

- 1 Evidence of leakage or loss of pressure.
- 2 Distortion or yielding of anchors, expansion hardware, the bellows and other piping components.
- 3 Any unanticipated movement of the piping due to pressure.
- 4 Evidence of instability in the bellows.
- 5 The guides, expansion joints, and other movable parts of the system should be inspected for evidence of binding.
- 6 Any evidence of abnormality or damage should be reviewed and evaluated by competent design authority.

Periodic Inservice Inspection

WARNING: Extreme care must be exercised while inspecting any pressurised system or component.

- 1 Immediately after placing the system in operation, a visual inspection should be conducted to insure that the thermal expansion is being absorbed by the expansion joints in the manner for which they were designed.
- 2 The bellows should be inspected for evidence of unanticipated vibration.
- 3 A program of periodic inspection should be planned and conducted throughout the operating life of the system. The frequency of these inspections should be determined by the service and environmental conditions involved. Such inspections can pinpoint the more obvious potential problems such as external corrosion, loosening of threaded fasteners, and deterioration of anchors, guides and other hardware. It must be understood that this inspection programme, without any other backup information cannot give evidence of damage due to fatigue, stress corrosion or general internal corrosion. These can be the cause of sudden failures and generally occur without any visual or audible warning.
- 4 When any inspection reveals evidence of malfunction, damage or deterioration, this should be reviewed by competent design authority for resolution. Additionally, any changes in the system operating conditions such as pressure, temperature, movement, flow, velocity, etc that may adversely affect the expansion joint should be reported to, and evaluated by, a competent design authority.

PTO...

For more information please call our sales engineers on 01663 748 200

All Thermosel® products are made by Pearwalk Engineering Ltd.
Furness Vale Business Centre, Calico Lane, Station Road, High Peak, SK23 7SW England
Tel: 01663 748 200 | Fax: 01663 746 834 | www.pearwalkengineering.com

THERMOSEL®

DESIGN STANDARDS

All standard units are designed to Thermosel® standard formulae which have been verified by tests witnessed by independent testing authorities.

The designs also conform to the requirements of the internationally recognised standard E.J.M.A. (Expansion Joint Manufacturers Association) and the British Standard Code of Practice for selection joints for use in pressure systems.

Pearwalk Engineering Ltd is represented on the British Standard Committee responsible for the preparation of the latter.

QUALITY

It is our policy to maintain our product reliability and company service to industry at the highest level compatible with realistic costs.

The quality control and manufacturing procedures as specified on our website www.pearwalkengineering.com meet the requirements of all major company, national and international quality standards.

SURVEY SOCIETIES

Thermosel® units are acceptable to all National and International Survey Societies. Pearwalk Engineering has received either type approval or is approved by individual societies as a manufacturer of bellows expansion joints in accordance with the societies' Conditions of Survey and Witness of Tests during the course of manufacture.

Copies of type approval certificates are available upon request. An additional charge will be made for certification covering survey society approval on individual units which are not type approved.

ORDERING

The purchase order for standard units must identify the type of unit required by reference to the ordering code as follows:

Typical Part number: SAF/0100/16/001/NP16/150

Unit description / Nominal bore / Pressure rating / Type Number / End fittings / Lateral Movement (Double units only).

The unit price for standard units will be quoted on the current price list. Flange details must be stated on the purchase order in addition to the ordering code.

TEMPERATURE CORRECTION CHART

Pressure/Temperature compensation

20°C	100%
100°C	80%
200°C	68%
300°C	64%
400°C	60%
500°C	58%
600°C	55%

ALTERNATIVE COMPONENTS OR MATERIALS

Where the operating or environmental conditions exceed the limits specified for the standard unit range or where special end fittings are required, alternative units can be designed and supplied.

Typical variations include choice of material for the membranes and end fittings, multi-ply membrane construction and alternative end fittings such as screwed pipe ends, vee flanges or swivel flanges.

Please discuss your special requirements with our sales engineers.

RESERVATIONS

We reserve the right:

- in the interest of design improvement to alter the design specification without prior notice.
- to invoice at prices ruling at date of dispatch

FURTHER INFORMATION

For further information about Thermosel® products please visit our website at www.pearwalkengineering.com

Below is our list of standard parts:

UNIT DESCRIPTION

APS - Axial Pipe End Screwed
SAP - Single Axial Pipe End
SAPV - Single Axial Pipe End (Victaulic)
SAF - Single Axial Flanged
DAP - Double Axial Pipe End
DAF - Double Axial Flanged
DUP - Double Universal Pipe End
DUF - Double Universal Pipe End
SAV - Single Axial Van-Stone
DAV - Double Axial Van-Stone
STF - Single Tied Flanged
STP - Single Tied Pipe End
STPV - Single Tied Pipe End (Victaulic)
DTF - Double Tied Flanged
DTP - Double Tied Pipe End
DHF - Double Hinge Flanged
DHP - Double Hinge Pipe End
SHF - Single Hinge Flanged
SHP - Single Hinge Pipe End
SGF - Single Gimbal Flanged
SGP - Single Gimbal Pipe End
DGF - Double Gimbal Flanged
DGP - Double Gimbal Pipe End
SMP - Single Multi-Ply Pumpflex
SMT - Single Multi-ply Pumpflex Tied
TRB - Thermosel Rubber Bellows
MFS - Metallic Flexible Hose with Swivel Ends
HEX - Heat Exchanger Joint

TYPE NUMBERS:

001 - Carbon steel fittings no internal sleeve
002 - Carbon steel fittings single internal sleeve
003 - Carbon steel fittings telescopic internal sleeves
004 - Carbon steel fittings single internal sleeve, telescopic external sleeves
005 - Carbon steel fittings single internal sleeve, telescopic external sleeves
006 - Carbon steel fittings telescopic internal sleeves, telescopic external sleeves
007 - Carbon steel fittings no internal sleeve, shroud
008 - Carbon steel fittings single internal sleeve, shroud
009 - Carbon steel fittings telescopic sleeves, shroud
010 - Stainless steel fittings no internal sleeve
011 - Stainless steel fittings single internal sleeve
012 - Stainless steel fittings telescopic internal sleeves
013 - Stainless steel fittings no internal sleeve, telescopic external sleeves
014 - Stainless steel fittings single internal sleeve, telescopic external sleeves
015 - Stainless steel fittings telescopic internal sleeves, telescopic external sleeves
016 - Stainless steel fittings no internal sleeve, shroud
017 - Stainless steel fittings single internal sleeve, shroud
018 - Stainless steel fittings telescopic internal sleeves, shroud
020 - Twin Sphere Union (Neoprene)
021 - Single Sphere Flanged (Neoprene)
022 - Single Sphere Flanged Tied (Neoprene)
030 - Galvanised Fittings (fixed male & swivel female)
120 - Twin Sphere Union (E.P.D.M.)
121 - Twin Sphere Flanged (E.P.D.M.)
122 - Twin Sphere Flanged Tied (E.P.D.M.)

END FITTINGS:

PN6 - Drilled
PN16 - Drilled
PN25 - Drilled
PN40 - Drilled
BS10A - BS10 Table A
BS10D - BS10 Table D
BS10E - BS10 Table E
BS10F - BS10 Table F
BS10H - BS10 Table H
ASA150
ASA300
JIS 5k - Drilled
JIS 10K - Drilled
JIS 16K - Drilled
JIS 20K - Drilled

NOMINAL BORE:
0015 - 4000 mm

PRESSURE RATINGS:
2.5 bar
10 bar
16 bar
25 bar

For more information please call our sales engineers on 01663 748 200

All Thermosel® products are made by Pearwalk Engineering Ltd.

Furness Vale Business Centre, Calico Lane, Station Road, High Peak, SK23 7SW England

Tel: 01663 748 200 | Fax: 01663 746 834 | www.pearwalkengineering.com

THERMOSEL®